

### General information

Cavitation Tunnel has a long time experience in measurements of the performances of propellers in cavitation conditions, including side effects such as induced pressures and radiated noise. To this aim pressure sensors and hydrophones are used. Tests have been carried out on different propeller types during years, including conventional FPP and CPP, contrarotating propellers, CLT propellers, ducted propellers, side thrusters, SPP, cooperating with various industries/partners such as CETENA, Detra, Eliche Radice, Fincantieri, Lame, Flexitab, Sistemar, ZF Marine.

A specific field of research is focused on the problem of direct measurements of the cavitation volume, while full scale observations of the cavitation performances of propellers have been performed through windows placed on the stern of ships

Finally, tunnel is also equipped with instrumentation for non-intrusive measurement of velocity field, i.e. Laser Doppler Velocimetry (LDV).

### Description of the test facility

The facility is a Kempf & Remmers closed water circuit tunnel with a squared testing section of 0.57 m x 0.57 m, having a total length of 2 m. Optical access to the testing section is possible through large windows.

The nozzle contraction ratio is 4.6:1, and the maximum flow speed in the testing section is 8.5 m/s. Vertical distance between horizontal ducts is 4.54 m, while horizontal distance between vertical ducts is 8.15 m.

A depressurization system allows obtaining an atmospheric pressure in the circuit near to vacuum, in order to simulate the correct cavitation index for propellers and profiles (2D and 3D).

The tunnel is equipped with a Kempf & Remmers H39 dynamometer, which measures propeller thrust, torque and RPM. Maximum measurable values are reported in the following table:

Thrust	+/- 981 N
Torque	+/- 49.05 N m
RPM	+/- 3000 RPM

As usual, a mobile stroboscopic system allows to visualize cavitation phenomena on the propeller blades. Moreover, cavitation phenomena visualization in the testing section is also made with a certain number (usually two/three) of cameras. Allied Vision Tech Marlin F145B2 Firewire Cameras, with a resolution of 1392 x 1040 pixels and a frame rate up to 10 fps are currently adopted.

Radiated noise is measured by means of Reson TC4013 hydrophone and pressure pulses by means of Kulite pressure gauges.

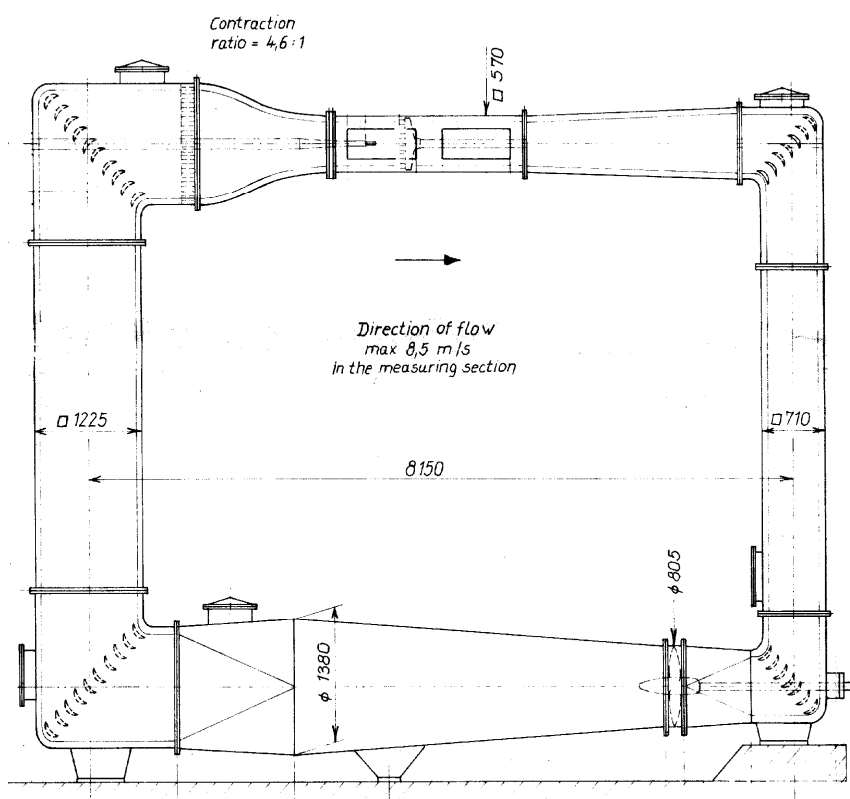

# CONVENTIONAL PROPELLERS

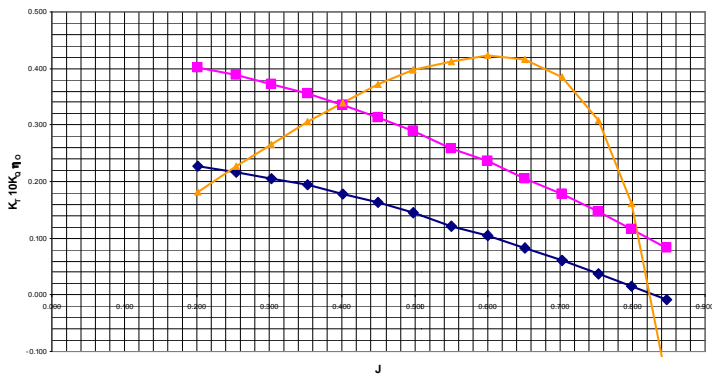

Mechanical characteristics

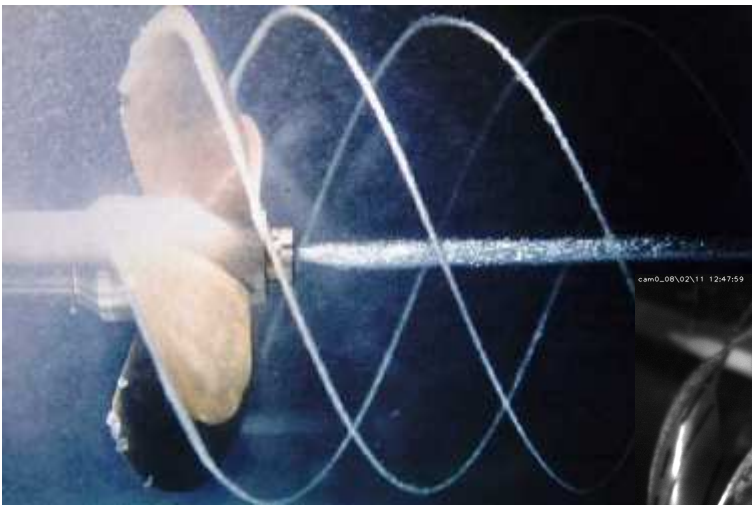

Cavitation observations

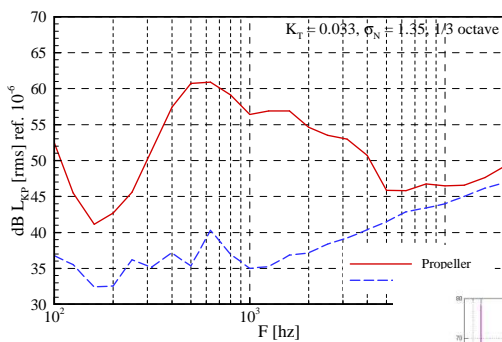

Radiated noise

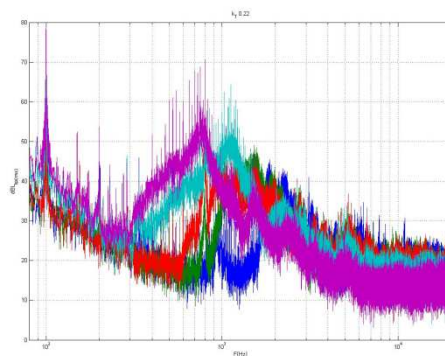

# UNCONVENTIONAL PROPELLERS

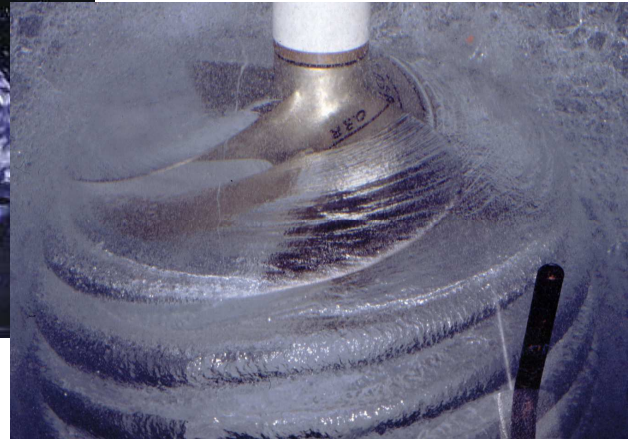
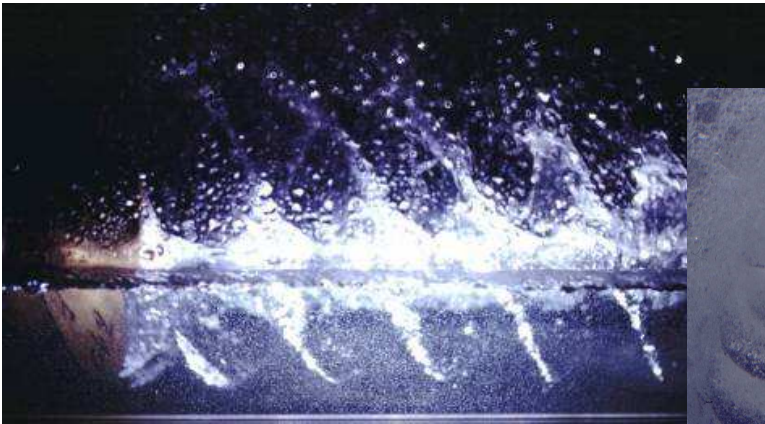

SPP

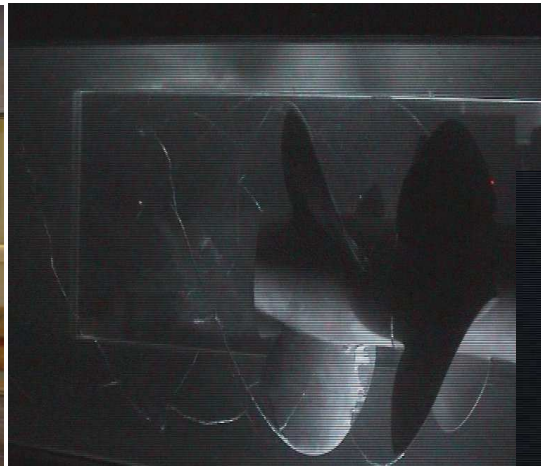
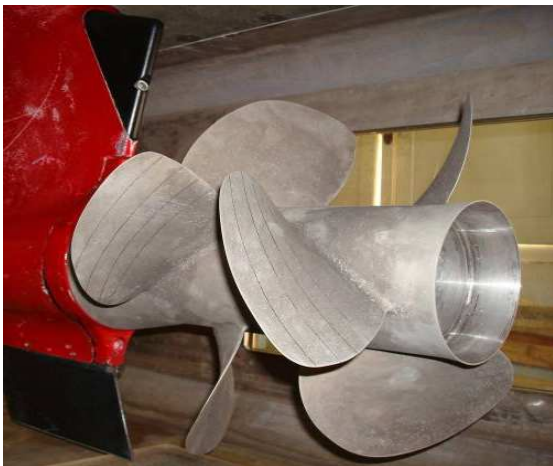

CONTRAROTATING



CLT

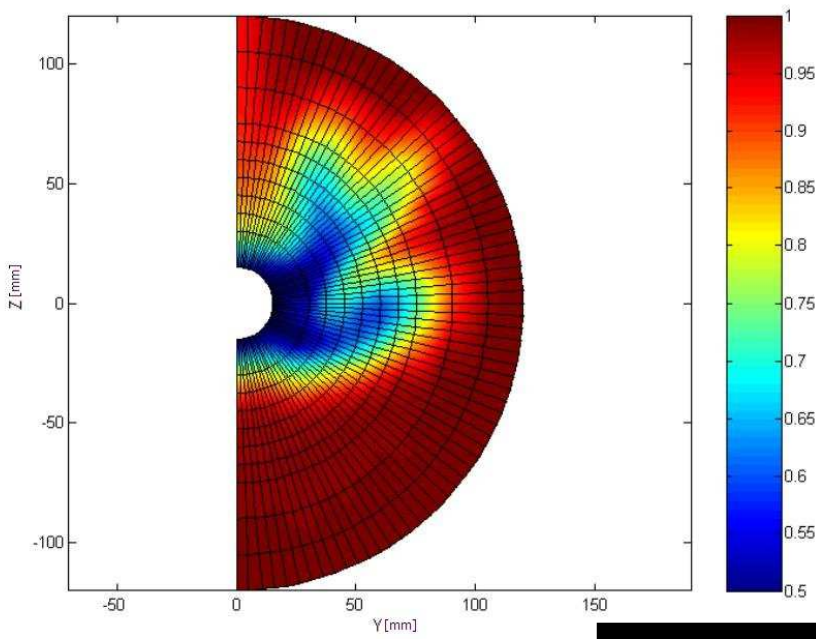
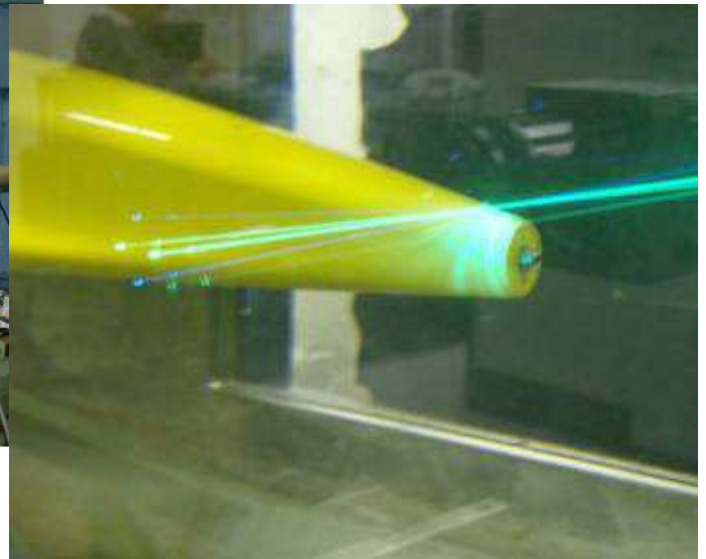

Propeller flow  
characterisation

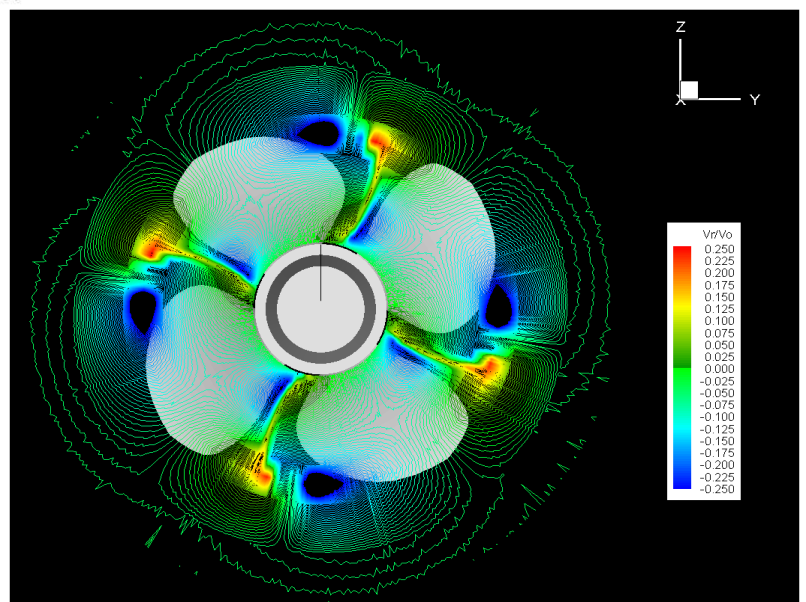

# CAVITATION 3D RECONSTRUCTION

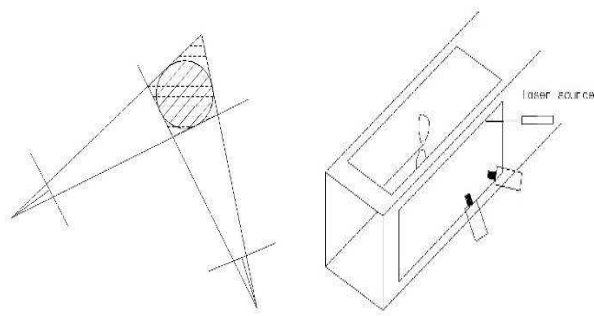

STEREOMETRY

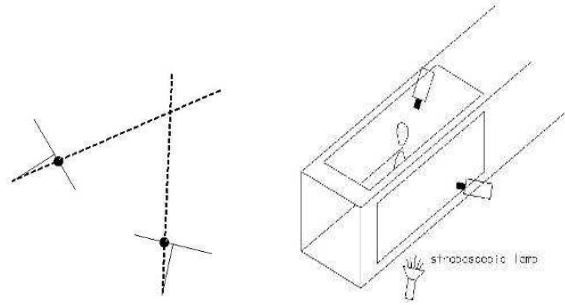

ACTIVE STEREO

STEREOMETRY  
RECONSTRUCTION  
SHEET CAVITATION

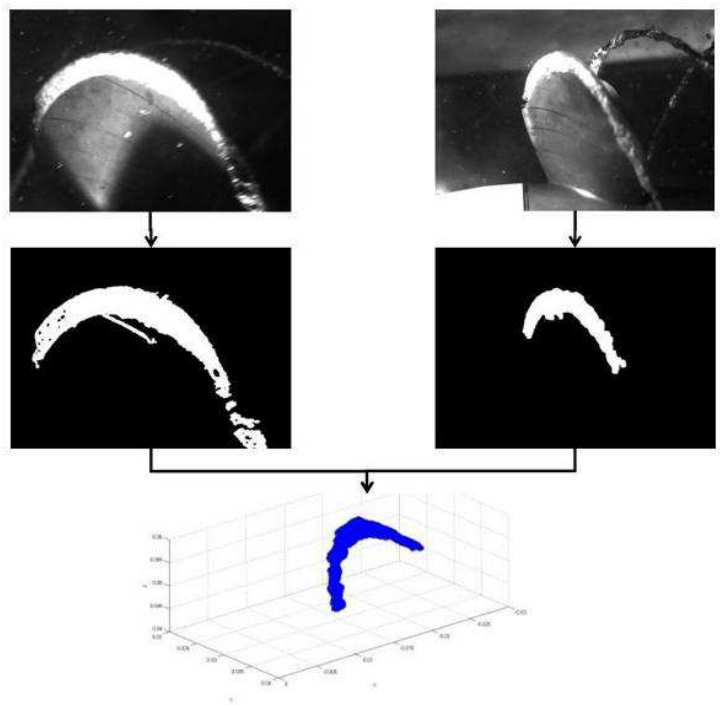

## FULL SCALE OBSERVATIONS

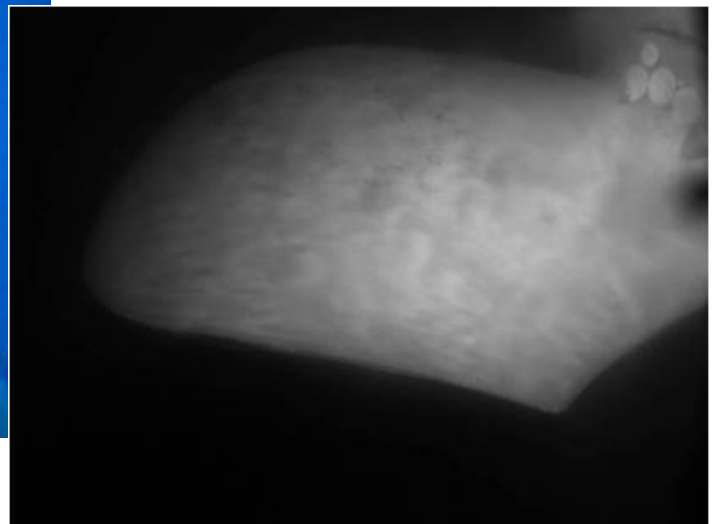

## DITEN - Towing Tank

DITEN Hydrodynamic Laboratories include also a Towing Tank (dimensions about 60x2.5x3 m) provided with dynamometric carriage (maximum speed about 3 m/s) with capability of measurement of ship trim and resistance

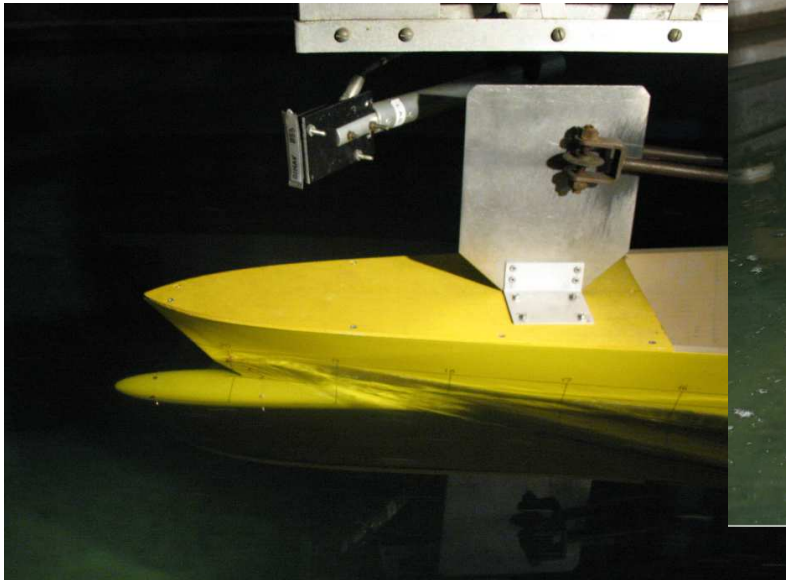
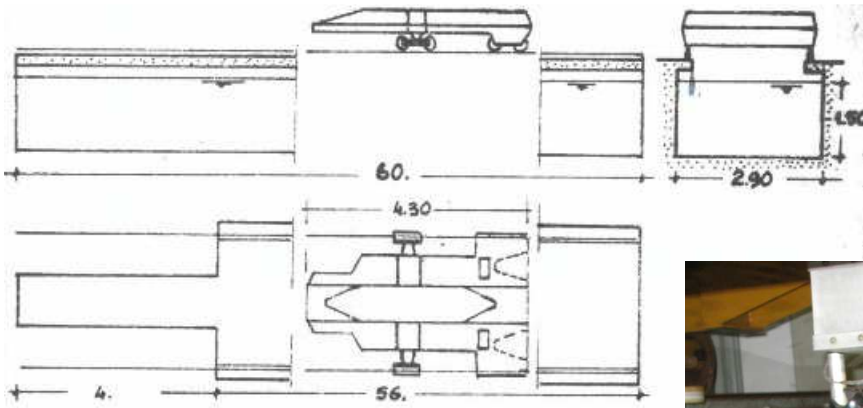

**Marine Advanced Testing & Sea Trials**



DITEN – Università degli Studi di Genova

Viale Cambiaso 6, 16145 Genova (Italy)

For more information:

ing. Michele Viviani

tel. + 39 010 353 int.2547/2438/2425